

**INNOVATIVE
& CREATIVE DESIGNER GROUP
WITH PASSION, EFFORTS & IDEA**

Welcome to visit us, we will be your best partner for
design of high pressure & high temperature applications.

(주)포스엔텍의 BMRS(Benchtop-scale Mini Reaction System)은 중.대형 크기의 실험용 Reaction system의 모든 기능 및 성능을 갖추면서 운전자가 손쉽게 취급할 수 있도록 고려된 콤팩트한 디자인의 반응 시스템입니다.

당사의 BMRS 는 콤팩트한 디자인으로 여러분의 실험실 공간을 매우 적게 차지할 것입니다. 또한 다양한 내용적, 사용압력, 사용온도 및 다양한 재질로 제작되어질 수 있습니다.

- * Available internal volume : up to 500cc
- * Design temperature range : Max. 315°C (STS316)
 - 특수소재(HC-276, Inconel등)의 경우에는 해당소재의 물리적특성에 따라 더 고온의 조건으로도 디자인 될 수 있습니다.
- * Design pressure range : Max. 344.8 bar @ 200°C (standard)
 - 더 높은 압력 및 온도 조건의 디자인도 가능합니다.



BENCHTOP SCALE MINI REACTION SYSTEMS

INNOVATIVE
& CREATIVE DESIGNER GROUP
WITH PASSION, EFFORTS & IDEA

PHOS-ENTECH CO.,LTD.

www.phosentech.com

표준구성(STANDARD)



- * 반응기(REACTOR) : STS316 (STANDARD)
 - Closure type : bolt closure
- * ELECTRIC FURNACE : CERAMIC BAND HEATER TYPE
- * PRESSURE GAUGE(1EA)
- * RELIEF VALVE(1EA)
- * VALVES (2EA)
- * THERMOCOUPLES(2EA)
- * BENCHTOP STAND
- * CONTROL BOX

옵션(OPTIONS)

- * Material : Hastelloy C-276, Inconel 625, Monel , etc.
- * Main seal : O-Ring, Metal gasket, Teflon flat type gasket, Graphite flat type gasket, etc.
- * 교반기(AGITATOR) : MAGNTIC DRIVEN TYPE
 - Motor set included
- * Internal cooling coil
 - 내용적 300 cc 이상만 적용
- * Vise stand assembly
- * Torque wrench

용도(APPLICATIONS)

- * Chemical Reaction
- * Petrochemical Reaction
- * Environmental Reaction
- * etc.



REACTOR ASSEMBLY



DISASSEMBED FURNACE

BENCHTOP SCALE MINI REACTION SYSTEMS

INNOVATIVE
& CREATIVE DESIGNER GROUP
WITH PASSION, EFFORTS & IDEA

PHOS-ENTECH CO.,LTD.

www.phosentech.com

표준모델 사양 (Specifications of Standard models)

MODEL NO.	BMRS-150-MD	BMRS-200-MD	BMRS-300-MD	BMRS-500-MD
Internal volume(mL)	150	200	300	500
Design condition	207 bar @ 315°C			
Internal size(mm)	I.D.50 × I.L.90	I.D.50 × I.L.119	I.D.50 × I.L.155	I.D.60 × I.L.185
Main seal	Metal gasket			
Material(wet parts)	STS316			
Furnace (watts)	450	600	750	1000
Agitator type	Magnetic driven agitator			
Agitator motor	Speed control motor, 90 Watts			
Impeller type	Pitched turbine blade type			
Impeller stages	1	1	1	1
Agitator-motor connection belt	Timing belt			
Spare parts	Metal gasket (1ea), Main bolt용 비트 소켓(토크렌치는 제외)			
Electricity	AC220V, 1-ph, 60hz			
Overall demension (W×D×H), mm	265W×475D×620H	265W×475D×625H	265W×475D×680H	300W×490D×750H
Weight(kg),approx.	32	33	36	40

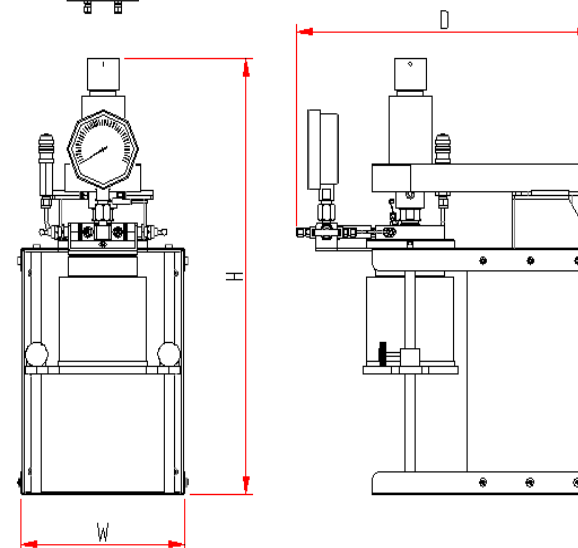
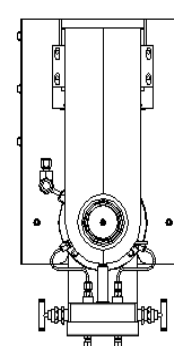

다른 온도, 압력, 재질 및 기타 요구사항에 대해서도 모두 협의하여 제작 가능합니다.